

GRINDING HEAD

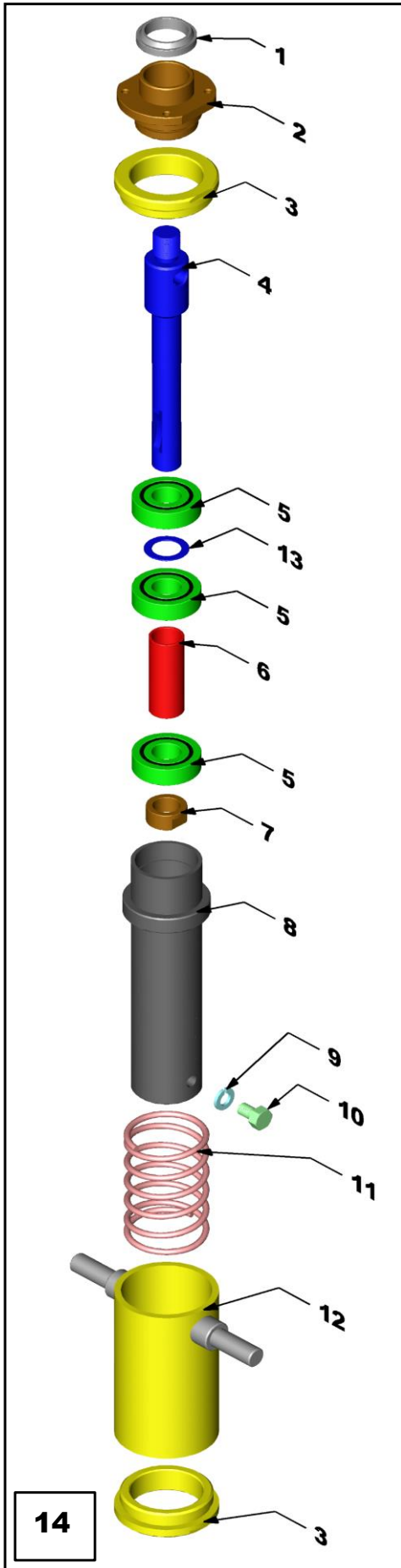

NO.	DESCRIPTION	PART NO.	QTY.
1	SEAL, WIPER (DUST)	680A1	1
2	CAP, BEARING	305D2	1
3	CAP, OUTER SHELL	305E1	2
4	SPINDLE, GRINDING HEAD	155BS1	1
5	BALL BEARING	140C300	3
6	SPACER	200E6	1
7	NUT, LOCK	210D1	1
8	SHELL, HOUSING	105BG1	1
9	WASHER, LOCK	285A312	1
10	BOLT, HEX HEAD	280A303	1
11	SPRING, COMPRESSION	465C1	1
12	SHELL, OUTER	105BH1	1
13	SPACER, BEARING	200AX1	1
14	GRINDING HEAD ASSEMBLY	25AM1	1

GUARD

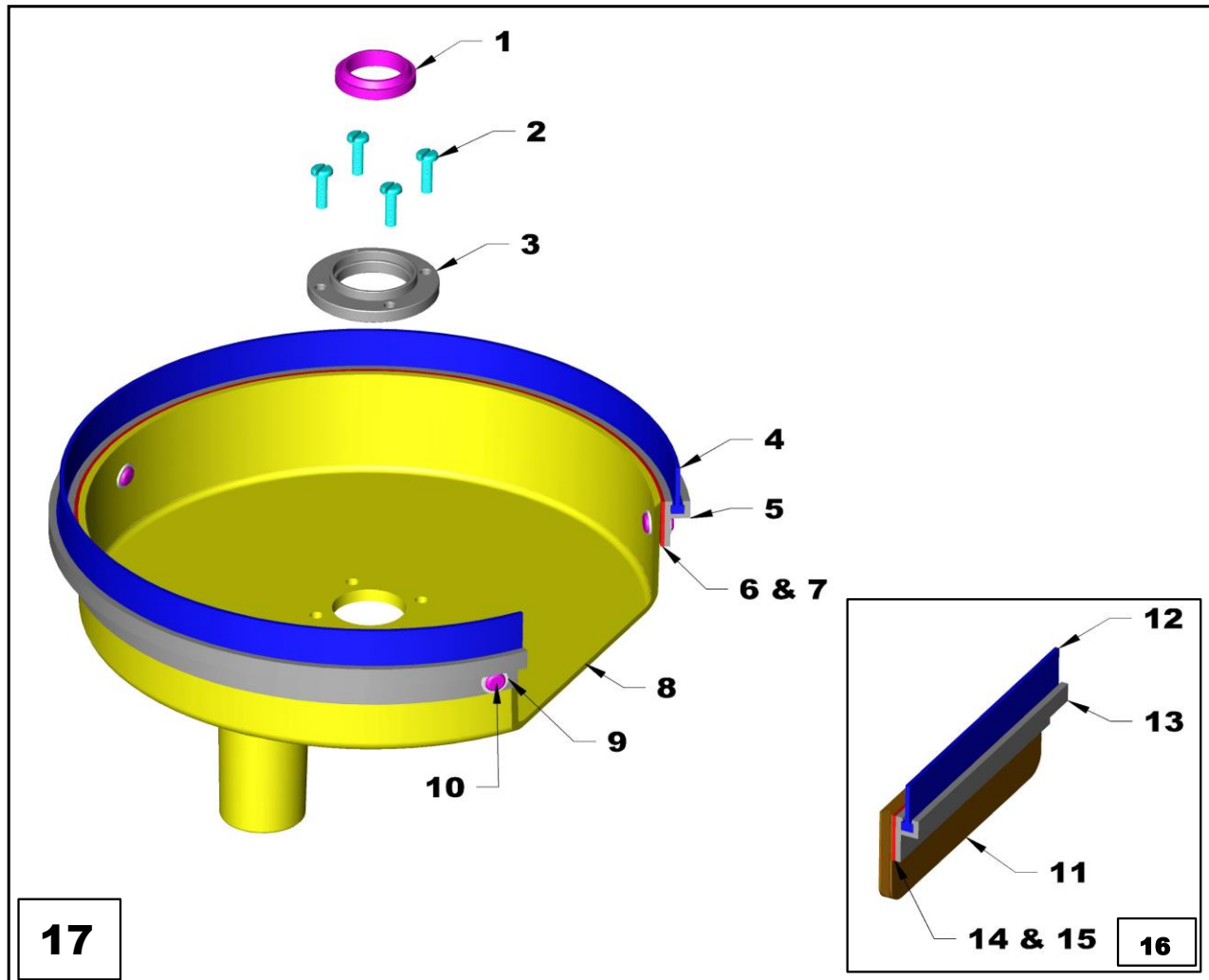

NO.	DESCRIPTION	PART NO.	QTY.
1	SEAL, WIPER (DUST)	680A1	1
2	SCREW, PAN HEAD	190F175	4
3	WASHER, GUARD	370G1	1
4	BRUSH, GUARD	670B1	1
5	BRUSH, HOLDER	495C1	1
6	TAPE, DOUBLE SIDED	675B1	1
7	TAPE, DOUBLE SIDED	675D1	1
8	GUARD, VACUUM	270E2	1
9	WASHER, FLAT	370A10	3
10	RIVET, BLIND	545B1	3
11	GUARD, VACUUM	270F2	1
12	BRUSH, GUARD	670A1	1
13	BRUSH, HOLDER	495B1	1
14	TAPE, DOUBLE SIDED	675A1	1
15	TAPE, DOUBLE SIDED	675C1	1
16	GUARD, VACUUM (ASSEMBLY)	270F1	1
17	GUARD, VACUUM (ASSEMBLY)	270E3	1

ELECTRIC POWER UNIT

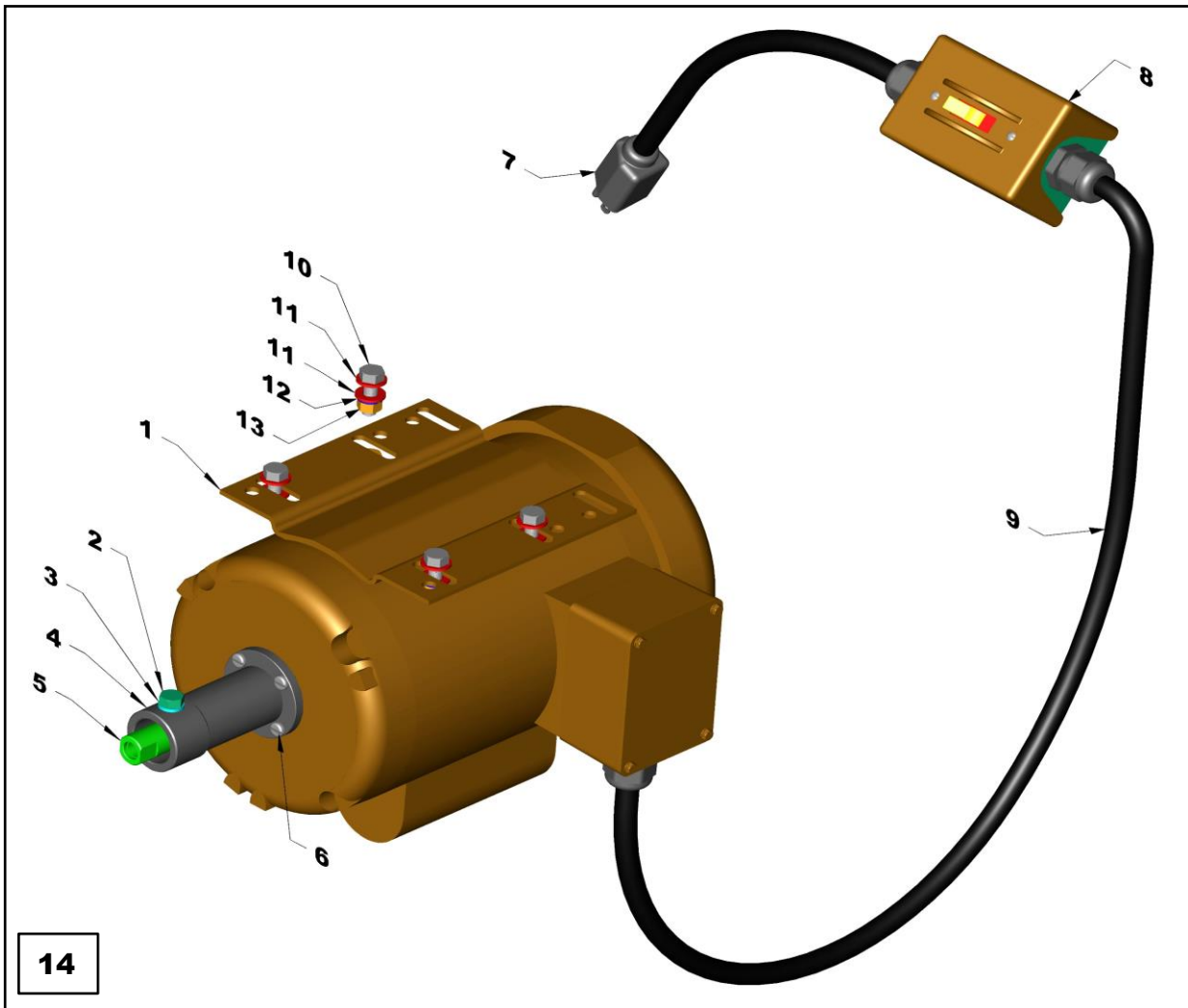

NO.	DESCRIPTION	PART NO.	QTY.
1	ELECTRIC MOTOR, 1 1/2 HP	555B1	1
1A	ELECTRIC MOTOR ASSEMBLY (with 1,4,5,6)	555B2	1
2	BOLT, HEX HEAD	280A303	1
3	WASHER, LOCK	285A312	1
4	CASING ADAPTER (w / hardware)	150HK2	1
5	CORE ADAPTER	160ED2	1
6	SCREW, PAN HEAD	190F175	4
7	CORD, POWER	505A1	1
8	SWITCH, ELECTRIC	425D1	1
9	CORD, ELECTRIC	505E1	1
10	BOLT, HEX HEAD	280A308	4
11	WASHER, FLAT	370A312	8
12	WASHER, LOCK	285A312	4
13	NUT	211A31	4
14	ELECTRIC POWER UNIT (COMPLETE ASSEMBLY)	555B3	1

ELECTRIC MOTOR HANGER ASSEMBLY

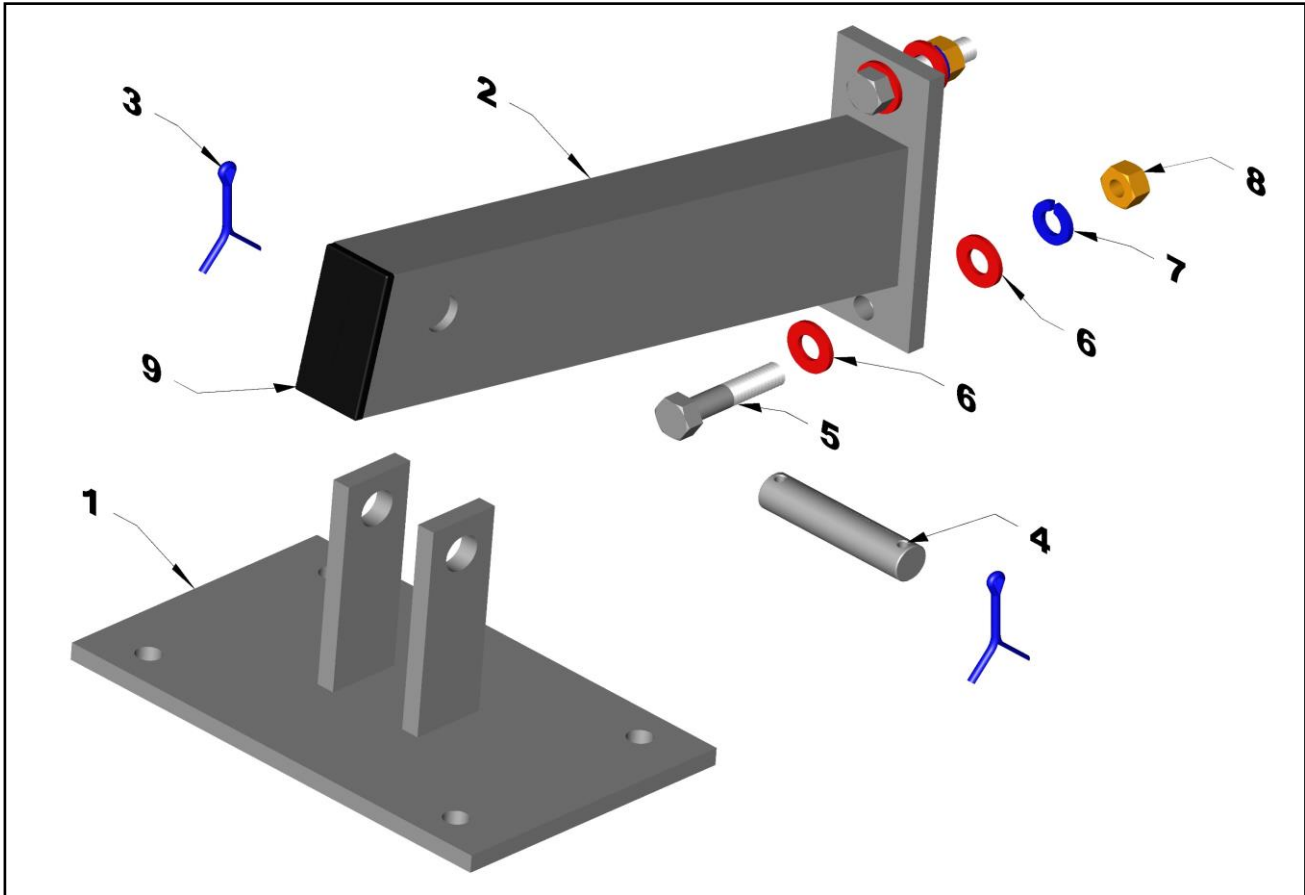

NO.	DESCRIPTION	PART NO.	QTY.
1	MOTOR PLATE	440M1	1
2	MOTOR HANGER	440L1	1
3	COTTER PIN	180E2	2
4	HINGE PIN	180D1	1
5	BOLT, HEX HEAD	280A315	2
6	WASHER, FLAT	370A312	4
7	WASHER, LOCK	285A312	2
8	NUT	211A31	2
9	END CAP	400M1	1

FLEXIBLE SHAFT ASSEMBLY

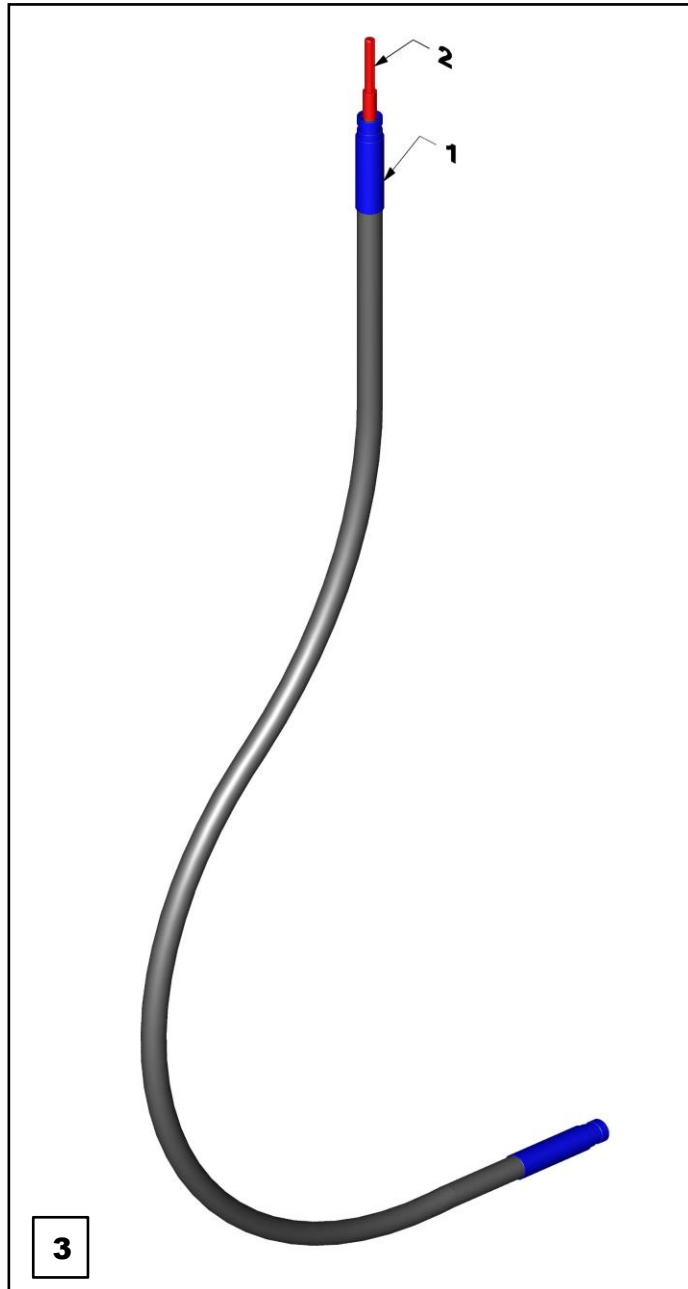

NO.	DESCRIPTION	PART NO.	QTY.
1	7' OUTER CASING	275Y7	1
2	7' INNER CORE	250T7	1
3	7' FLEXIBLE SHAFT ASSEMBLY	30AK7	1

BASE FRAME ASSEMBLY

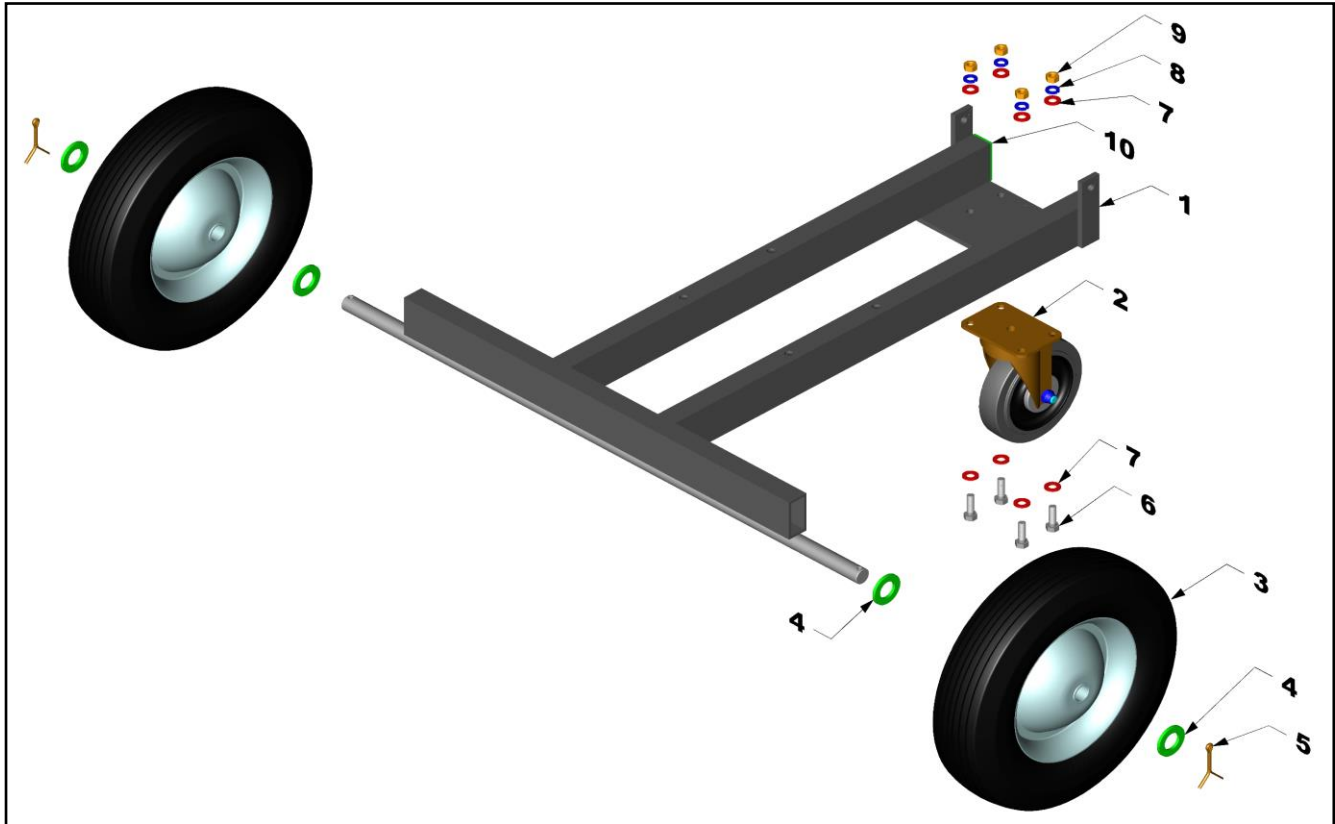

NO.	DESCRIPTION	PART NO.	QTY.
1	FRAME, BASE	440F1	1
2	SWIVEL CASTER	590B1	1
3	WHEEL, TIRE	590A1	2
4	WASHER, FLAT	370A750	4
5	COTTER PIN	180E1	2
6	BOLT, HEX HEAD	280A308	4
7	WASHER, FLAT	370A312	8
8	WASHER, LOCK	285A312	4
9	NUT	211A31	4
10	END CAP	400M1	2

MAIN FRAME ASSEMBLY

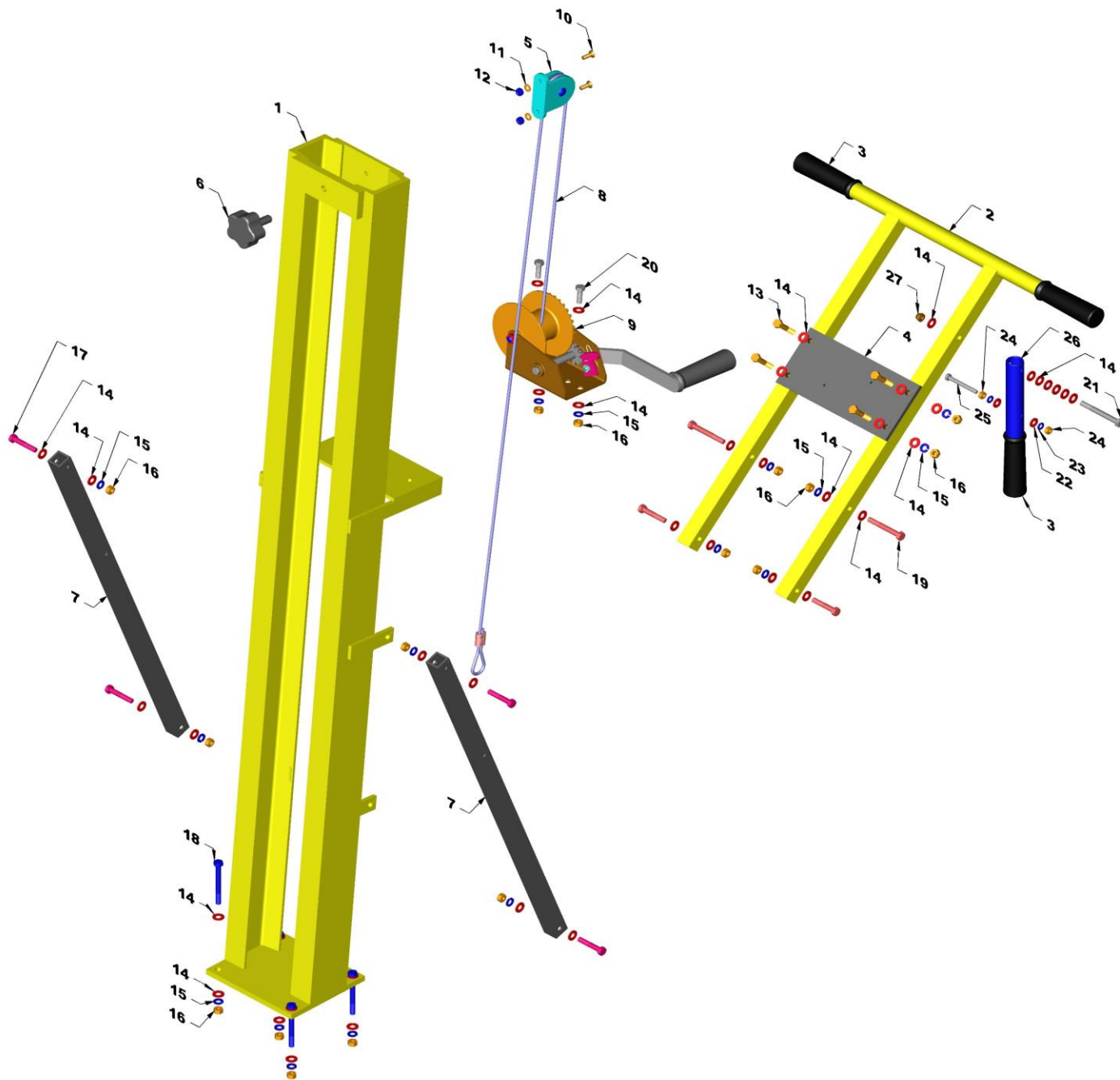

NO.	DESCRIPTION	PART NO.	QTY.
1	MAIN FRAME	440H1	1
2	HANDLE	165D1	1
2A	HANDLE (w / 3)	165D2	1
3	GRIP	165C1	2
4	PLATE, SWITCH	215AN1	1
5	PULLEY	590C1	1
6	LOCKING KNOB	365B1	1
7	SUPPORT TUBE	195G1	2
8	CABLE ASSEMBLY	315B2	1
9	WINCH	595A1	1
10	SCREW	190H1	2
11	WASHER, LOCK	285A250	2
12	NUT	211A25	2
13	BOLT, HEX HEAD	280A317	4
14	WASHER, FLAT	370A312	36
15	WASHER, LOCK	285A312	18
16	NUT	211A31	18
17	BOLT, HEX HEAD	280A317	4
18	BOLT, HEX HEAD	285A330	4
19	BOLT, HEX HEAD	285A325	4
20	BOLT, HEX HEAD	285A310	2
21	BOLT, HEX HEAD	285A330	1
22	WASHER, FLAT	370A250	2
23	WASHER, LOCK	285A250	2
24	NUT	211A25	2
25	LUG, CHAIN	280A222	1
26	HANDLE, TENSION	165E1	1
26A	HANDLE, TENSION (w / 3)	165E2	1
27	NUT, NYLOC	211B250	1

MAST & CROSS BEAM FRAME ASSEMBLY

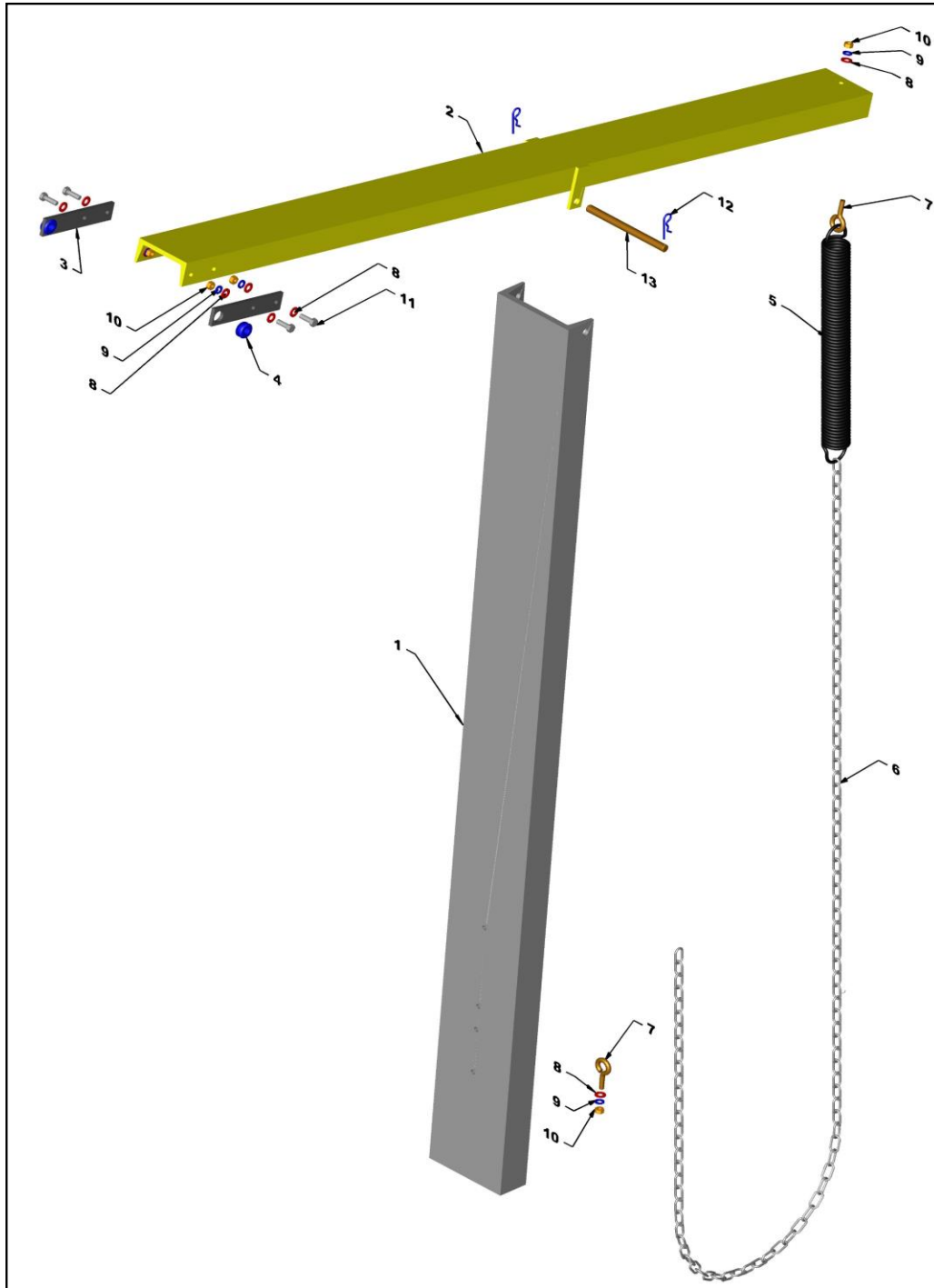

NO.	DESCRIPTION	PART NO.	QTY.
1	MAST	440K1	1
2	CROSS BEAM	440J2	1
3	PLATE (w / Grommet)	215AX2	2
4	GROMMET	130B1	2
5	SPRING, TENSION	465B1	1
6	CHAIN	315C1	1
7	EYE BOLT	570A1	2
8	WASHER, FLAT	370A312	10
9	WASHER, LOCK	285A312	6
10	NUT	211A31	6
11	BOLT, HEX HEAD	280A310	4
12	HITCH PIN	180E3	2
13	HINGE PIN	180C1	1

VACUUM ASSEMBLY

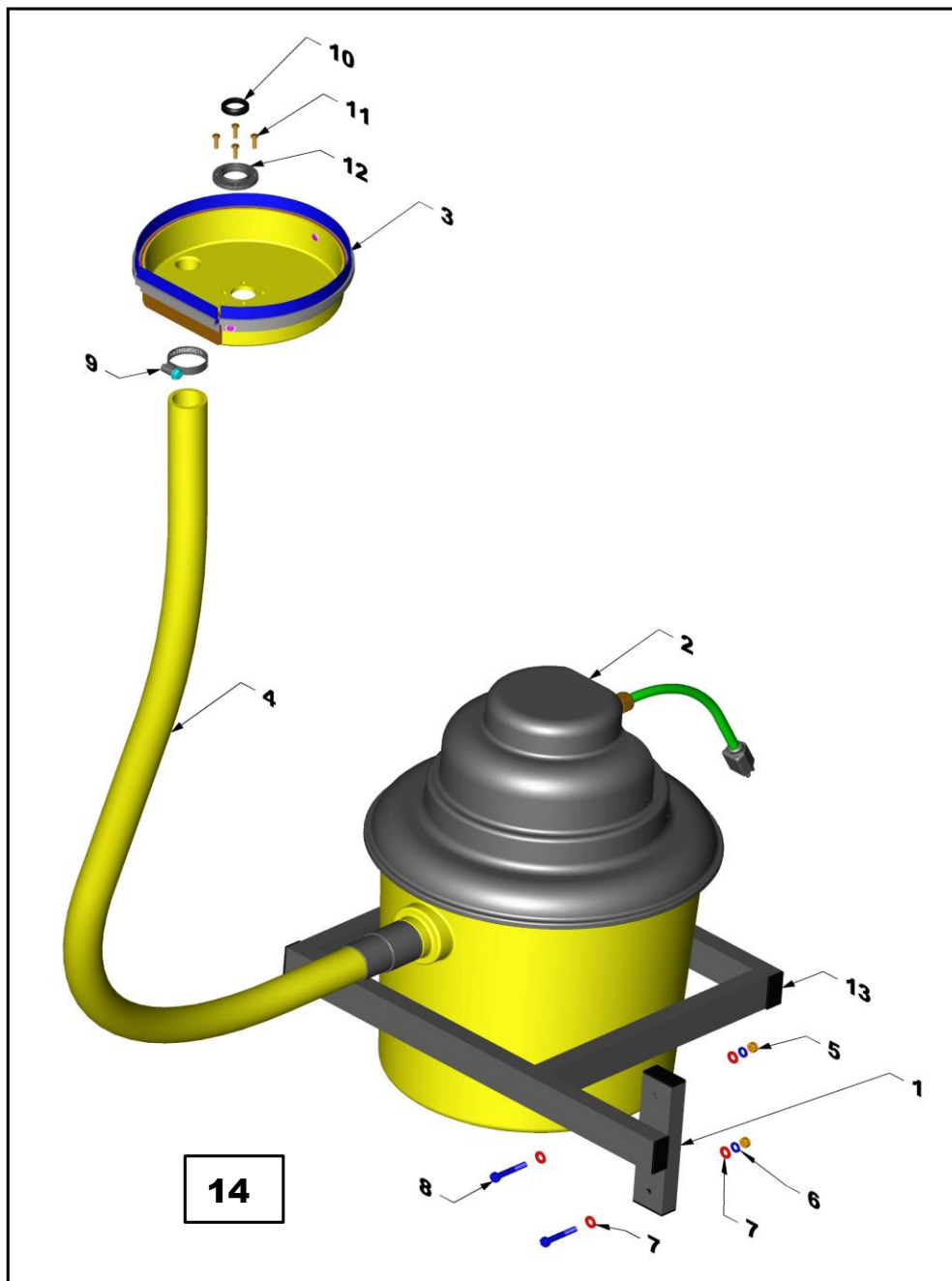

NO.	DESCRIPTION	PART NO.	QTY.
1	FRAME, VACUUM	440Y1	1
2	VACUUM	645A1	1
3	GUARD, VACUUM (ASSEMBLY)	270E3	1
4	HOSE, VACUUM	640A1	1
5	NUT	211A31	2
6	WASHER, LOCK	285A312	2
7	WASHER, FLAT	370A312	2
8	BOLT, HEX HEAD	280A320	2
9	CLAMP, HOSE	695A1	1
10	SEAL, WIPER (DUST)	680A1	1
11	SCREW, PAN HEAD	190F175	4
12	WASHER, GUARD	370G1	1
13	END CAP	400M1	6
14	VACUUM UNIT (COMPLETE ASSEMBLY)	645B1	1

DUAL VACUUM CART ASSEMBLY

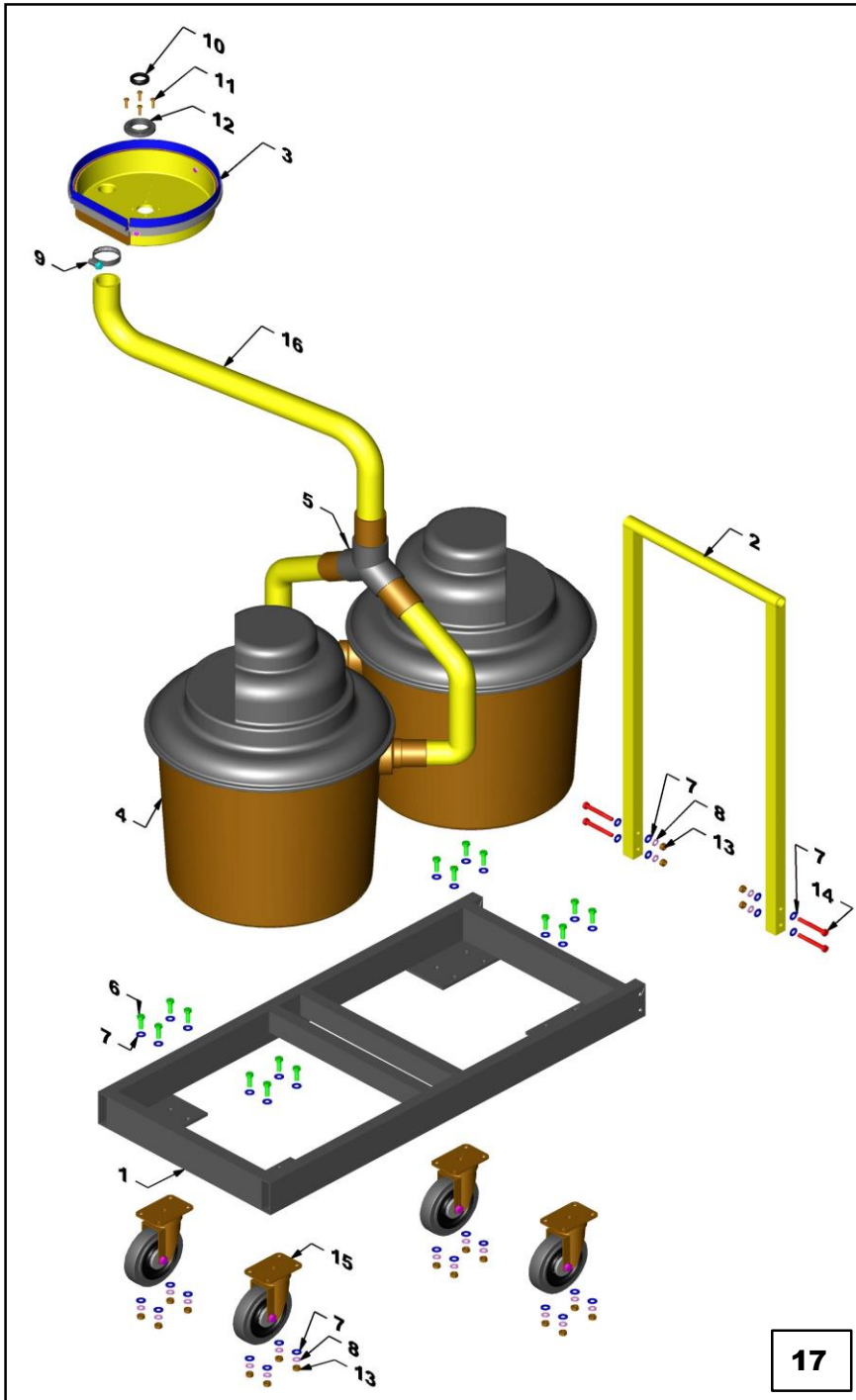

NO.	DESCRIPTION	PART NO.	QTY.
1	FRAME, MAIN	440AN1	1
2	HANDLE	440AP1	1
3	GUARD, VACUUM (ASSEMBLY)	270E3	1
4	VACUUM	645A1	2
4A	VACUUM (HEPA TYPE)	645A2	2
5	"Y" HOSE ADAPTER KIT (w/ 2 VACUUM HOSES)	640B1	1
6	BOLT, HEX HEAD	280A308	16
7	WASHER, FLAT	370A312	40
8	WASHER, LOCK	285A312	20
9	CLAMP, HOSE	695A1	1
10	SEAL, WIPER (DUST)	680A1	1
11	SCREW, PAN	190F175	4
12	WASHER, GUARD	370G1	1
13	NUT	211A31	20
14	BOLT, HEX HEAD	280A325	4
15	SWIVEL CASTER	590B1	4
16	HOSE, VACUUM	640A2	1
17	DUAL VACUUM CART ASSEMBLY	645B3	1
17A	DUAL VACUUM CART ASSEMBLY (HEPA TYPE)	645B3H	1